

Operating Instructions

Torque Transducer

Type CD1140 Series

Please read instruction carefully.

Important Advice:

The torque transducers of type **CD 1140** are suitable for applications in laboratories (for example in testing equipment) as well as in industrial environment.

The torque transducer is not designed with the usual safety factor (2...20), favoring high sensitivity instead.

Pay attention to the overload limit.

You have to protect users from danger of being hurt (metal cover etc.)

The torque transducer is not designed for explosion endangered areas.

Warranty is void if opened or disassembled.

The transducer must only be opened by authorized personnel.

1. Introduction

The torque transducers have different shafts according to measurement range. Torque transducers' measurement unit is Nm.

2. Application

Torque transducers are able to measure clockwise as well as counter clockwise torque. With clockwise torque the output is positive. The type label indicates the range of the transducer.

The torque transducers measure static torque as precise as dynamic torque. Yet you have to pay attention to the transducer's signal rise time. It is indicated in the Data sheet.

The torque transducers are maintenance-free.

Handle the torque transducer with care, especially when transporting or mounting. Because it can be damaged by hard shocks or by dropping to ground. Even a short peak torque above the allowed overload capacity can damage the measure shaft. In cases where this can happen you have to take precautions to avoid this.

The absolute maximum ratings regarding mechanical, thermal and electric parameters are listed in the data sheet and must be observed in design, mounting and operating.

3. Technical Details

3.1 Torque Shaft

The shaft is fixed in the chasing with two ball bearings.

To measure the torque it causes a proportional bending of the shaft (within the elastic range) and this is measured with applied strain gages. The strain gages are connected as a Wheatstone bridge. Additional angle or speed measurement is optionally available. (See the data sheet.)

3.2 Case

The case of the torque transducer is aluminum with a special surface.

The mounting of the torque transducer can be done either at foot or flange.

3.3. Measurement

The torque causes the bending of the shaft and the strain gages. The resistance of the strain gages changes proportional to the change of their length. And this is converted into an electrical signal that causes a frequency modulation. This modulated signal is transmitted optically to an electronic circuit in the casing. There it is converted back to a proportional analog output voltage. This output voltage has a separate ground that is electrically separated from the transducer's supply.

For speed and angle measurement the pulses of a code wheel are encoded to a square wave signal. With option speed measurement the output is 60 pulses per revolution, with option angle measurement two square wave signals are provided with an output of 360 pulses per revolution. While clockwise rotation the signal of channel A is approximately 90 degrees ahead of channel B.

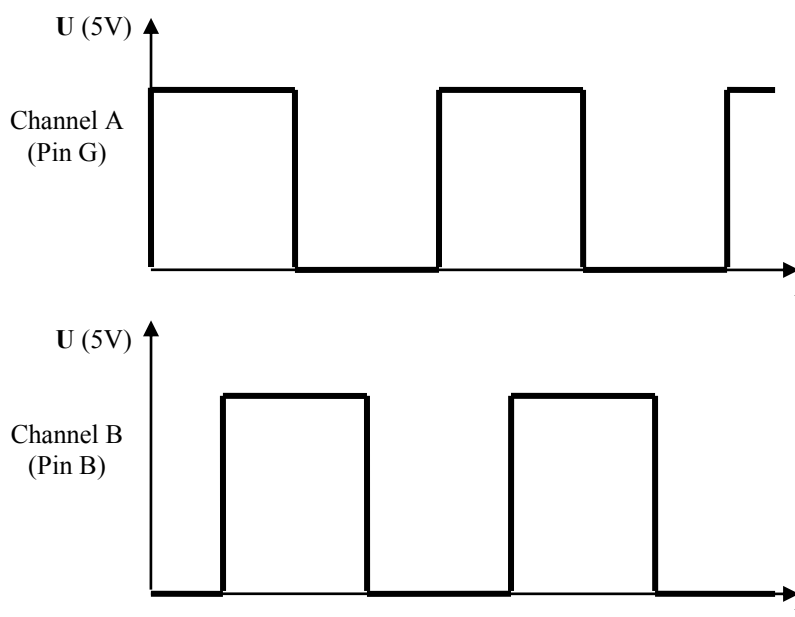

Technical changes reserved, LMig_2015-10-27_40e

3.4 Disturbances and their Compensation

Avoid bending, axial and radial forces. When you have problems with this, use clutches. To connect the transducer to a measurement unit you need a shielded cable.

The transducers are EMC-tested and are complying with EN 55011/03.91 (DIN VDE 0875-11/07.92) respective prEN 50082-2/1993 (E DIN EN 50082-2/03.94).

4. Operating conditions

4.1 Environment Temperature

For best accuracy you have to meet the environment temperature specification. The temperature should be constant or slowly changing. The specified temperature errors apply only for changes less than 5 K/h. Radiation heat or cooling on one side has to be avoided. Or appropriate precautions have to be taken.

4.2 Humidity and Dust

The torque transducer comply to IP40 after DIN 40050

Advice: Don't let humidity seep into the transducer's connector!

4.3 Chemically Resistance

The torque transducers are not resistant against chemicals.

4.4 Deposition

Dust, dirt and other particles mustn't accumulate so that they can get into the ball bearings and the connector.

5. Mounting

5.1 Precautions at Assembly

- * Handle the transducer carefully
- * Do not overload the transducer, not even temporarily. If possible, we suggest to connect the transducer to a display unit before mounting, so you can watch the torque while mounting.
- * Avoid false axial and radial alignment.
- * Provide good electrical ground contact to the casing.

Technical changes reserved, LMig_2015-10-27_40e

5.2 General Mounting Instructions

Don't mix up the transducer's drive side and the measuring side, as this causes errors (especially when accelerated).

When you look at the type label the measuring side is on the left.

On some torque transducers CD 1140 type the measuring side can be identified by a deepening on the cover.

Bending, axial and radial forces are causing errors. Keep thermal expanding of the construction in mind.

6. Measuring Chain

For measuring with the transducer, a whole measuring chain is necessary.

- * torque transducer
- * Measuring cable
- * Supply and display unit
- * Printer (when needed)

You need a supply and display unit to supply the transducer with power and to display the measured torque.

7. Connection

Connection of a torque transducer with 6pin plug

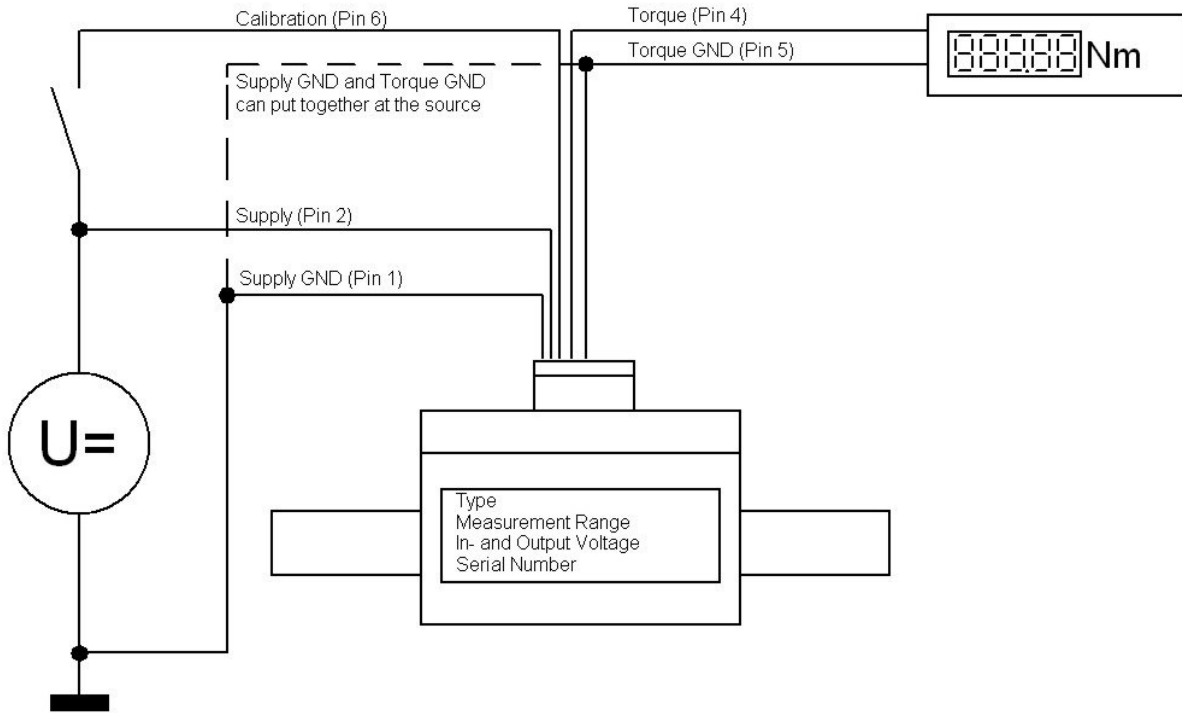

Connection of a torque transducer with 12pin plug

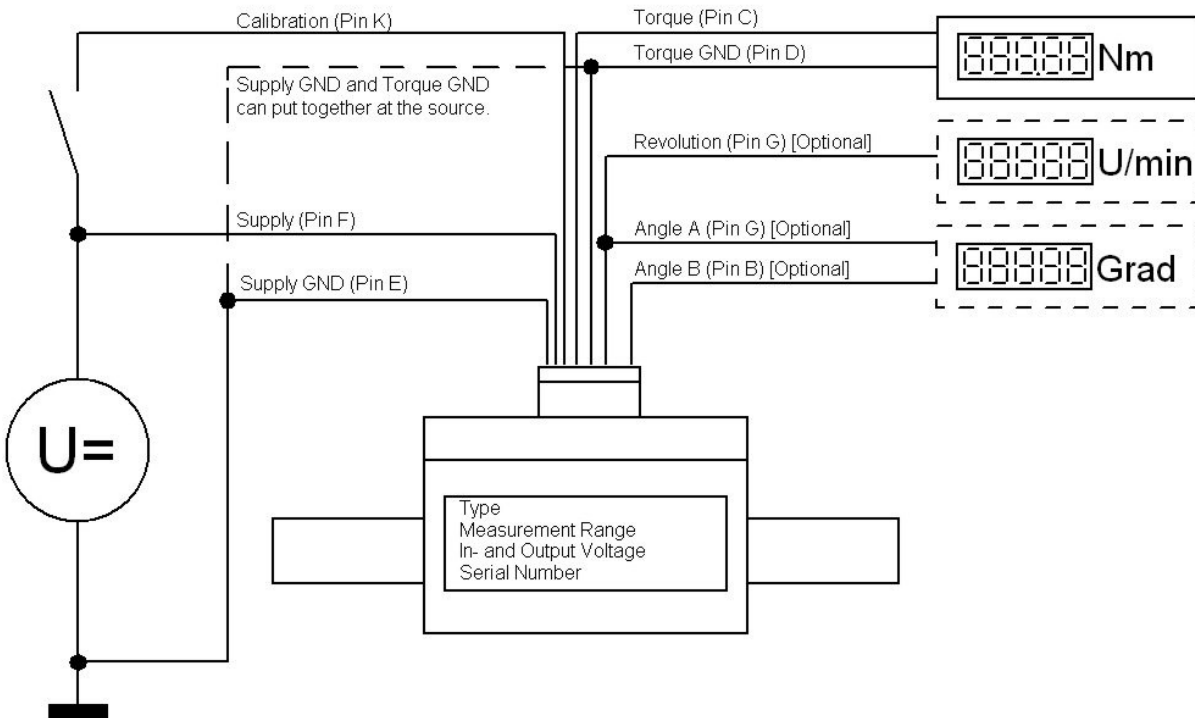

Technical changes reserved, LMig_2015-10-27_40e

7.1 Hints for Connection

Electric and magnetic fields cause interference with the measuring signal. This interference is mainly caused by power cords, relays or motors installed nearby. Besides these, interference can be caused by multiple grounding of the measurement chain on more than one point.

Pay attention to the following:

- * Use only shielded cables with low capacitance (like our measuring cables).
- * Connect supply voltage correctly (no reverse polarity protection).
- * Measuring cables shouldn't be nearby high voltage or control cables.
- * Magnetic radiation from transformers, motors or relays must be avoided.
- * Don't ground transducer and display unit multiple. Connect all devices of the measurement chain to the same ground.

7.2 Connectors

The transducer is equipped with a 6 or 12 pin fitted connector.

7.3 Pinout of the Connector

The pinout of the connector can be found at the end of this manual.

The transducer gives an internal galvanically isolated measurement signal. The grounds for supply and signal must not be bridged at the transducer, this will cause measurement faults. If needed, bridging should happen on evaluation device.

The input to get calibration signal is for testing the transducer. With an energize level of 4,5 V DC up to supply voltage the transducer will give the maximum output signal for right handed torque.

7.4 Prolongation of Cable

Prolongation cables have to be shielded and of low capacity. We recommend the use of our cables.

Good electrical connection of the prolongation cables is essential. It is important to use a cable with sufficient diameter so that the voltage drop on the supply lines isn't too high.

7.5 Supply Voltage

Regard to the correct polarity. The rise time for the supply voltage of 12V \pm 10% (optional 15V +5%/-10%) should be less than 1ms, otherwise the DC/DC – converter at the electronics might not work properly.

Pin Configuration

Torque transducer without options

Connector: 6 pin

Model CD 1140

| Pin | Connection |
|-----|---------------------------------|
| 1 | Supply GND |
| 2 | Supply |
| 3 | shield |
| 4 | Torque |
| 5 | Torque GND |
| 6 | Input to get Calibration Signal |

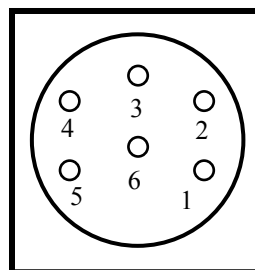

(Connector at the transducer, view from above)

PIN D (torque GND) and PIN E (supply and speed GND) are internally separated. If necessary bridge at supply source (not at the transducer!).

Between Pin 1 and 2; between Pin 4 and 5 as well as between Pin 1 and 6 there is a high frequency bypass capacitor connected (100nF/50V). We recommend carrying out this EMI protection at the supply source as well.

Pin Configuration

Torque transducer without special option with A suffix

Connector: 12 pin

Model CD1140-A

| Pin | Connection |
|-----|---------------------------------|
| A | NA |
| B | NA |
| C | Torque |
| D | Torque GND |
| E | Supply GND |
| F | Supply |
| G | NA |
| H | NA |
| J | NA |
| K | Input to get Calibration Signal |
| L | NA |
| M | shield |

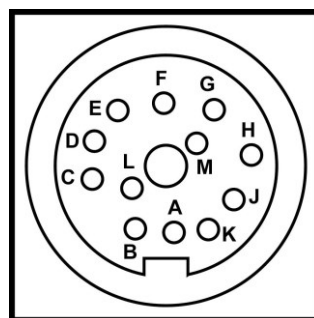

(Connector at the transducer, view from above)

PIN D (torque GND) and PIN E (supply and speed GND) are internally separated. If necessary bridge at supply source (not at the transducer!).

Between Pin E and K; between Pin E and F as well as between Pin C and D there is a high frequency bypass capacitor connected (100nF/50V). We recommend carrying out this EMI protection at the supply source as well.

Technical changes reserved, LMig_2015-10-27_40e

Pin Configuration

Torque transducer with **speed sensing**

Connector: 12 pin

Model CD1140-N

| Pin | Connection |
|-----|---------------------------------|
| A | NA |
| B | NA |
| C | Torque |
| D | Torque GND |
| E | Supply GND and Speed GND |
| F | Supply |
| G | Speed |
| H | NA |
| J | NA |
| K | Input to get Calibration Signal |
| L | NA |
| M | shield |

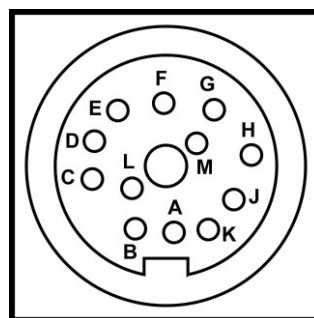

(Connector at the transducer, view from above)

PIN D (torque GND) and PIN E (supply and speed GND) are internally separated. If necessary bridge at supply source (not at the transducer!).

Between Pin E and K; between Pin E and F as well as between Pin C and D there is a high frequency bypass capacitor connected (100nF/50V). We recommend carrying out this EMI protection at the supply source as well.

Technical changes reserved, LMig_2015-10-27_40e

Pin Configuration

Torque transducer with **angle sensing**

Connector: 12 pin

Model CD1140-W

| Pin | Connection |
|-----|---------------------------------|
| A | NA |
| B | Angle Track B=90° |
| C | Torque |
| D | Torque GND |
| E | Supply GND and Angle GND |
| F | Supply |
| G | Angle Track A=0° |
| H | NA |
| J | NA |
| K | Input to get Calibration Signal |
| L | NA |
| M | shield |

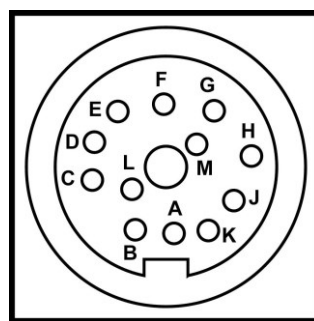

(Connector at the transducer, view from above)

PIN D (torque GND) and PIN E (supply and angle GND) are internally separated. If necessary bridge at supply source (not at transducer!).

Between Pin E and K; between Pin E and F as well as between Pin C and D there is a high frequency bypass capacitor connected (100nF/50V). We recommend carrying out this EMI protection at the supply source as well.

Technical changes reserved, LMig_2015-10-27_40e

8. Output

The transducer's output voltage is proportional to torque and $\pm 10V$ for maximum torque. With clockwise torque the output is positive; with counter clockwise torque the output voltage is negative.

The outputs for rotation speed and angle measurement have an open collector stage, with an internal 10 K Ω pull up resistor in series with a diode. See schematic below.

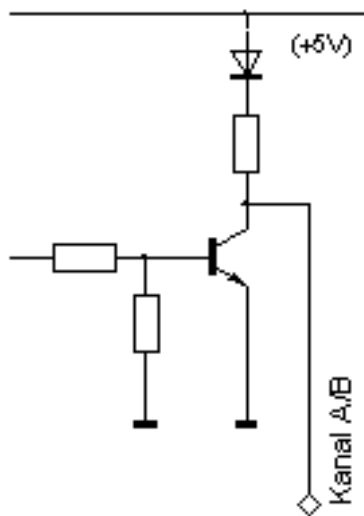

Angle and speed measurement at high rotation speeds:

(Transducers with 360 pulses per rotation)

- Remarks:**
- Beware of the maximum speed of your transducer type, listed in the data sheet!
 - **When you use a transducer with 60 pulses per rotation, the maximum speed is six times higher than listed below.**

With GMV2:

| Cable length: | Maximum speed: |
|---------------|----------------|
| 2.5 m / 8 ft | 10.000 RPM |
| 5 m / 41 ft | 10.000 RPM |
| 10 m / 33 ft | 6000 RPM |

With external measurement unit:

Maximum speed in RPM:

| Cable length | R pull up (to 5V ... 12V) | |
|--------------|---------------------------|--------|
| | 10 kΩ | 1,2 kΩ |
| 2,5 m / 8 ft | 4000 | 15.000 |
| 5 m / 41 ft | 2000 | 12.000 |
| 10 m / 33 ft | 1000 | 10.000 |

With this circuit you can measure speed of **more than 15,000 RPM** and with a cable of **up to 33 ft**. The signal level of the circuit on the left hand side is suitable for opto couplers, frequency counters, oscilloscopes and for (H)CMOS logic. If you need standard TTL levels you can add the circuit on the right hand side.

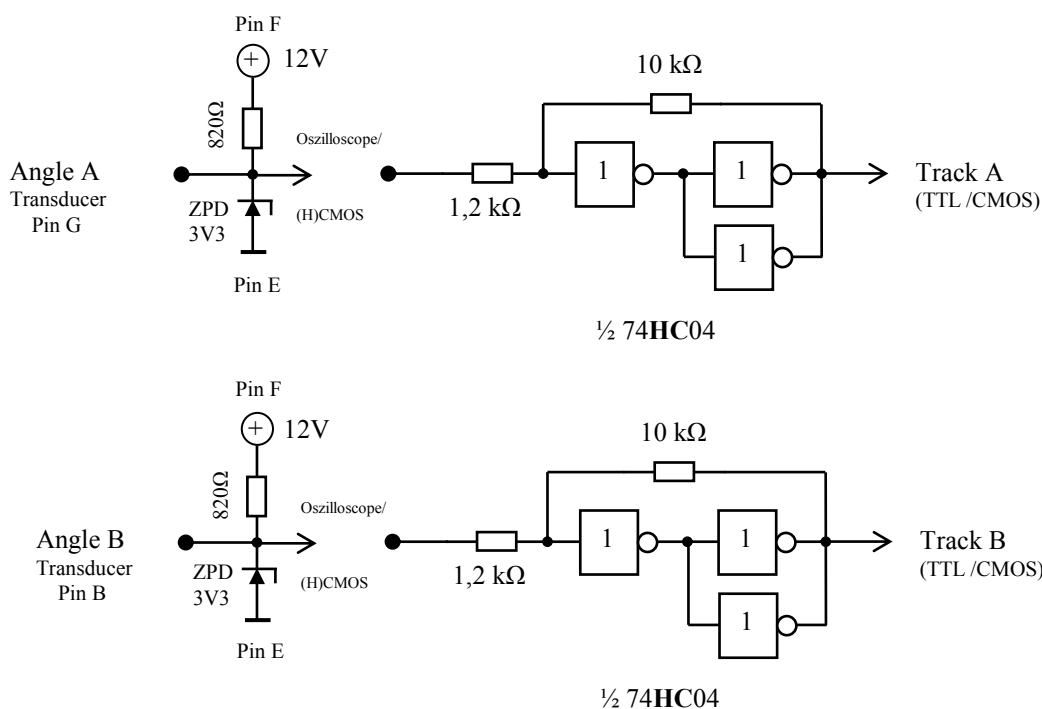

Technical changes reserved, LMig_2015-10-27_40e